

Installation, Operation and Maintenance Manual

3100, 3900, Series Control Dampers

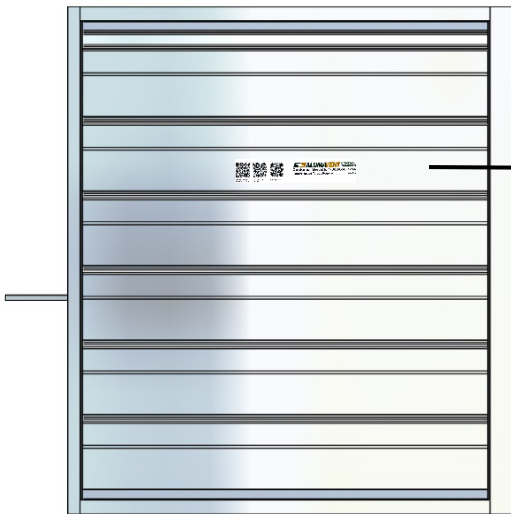

ALUMAVENT CONTROL DAMPERS
Customer Service: 1-800-668-7214
Factory Tested Torque Required: _____ in-lbs

Safety Warning

Please read the installation, operation, and maintenance instructions in whole preceding to installing or servicing. Incorrect installation, adjustment, change, service, or maintenance can cause property damage, injury, or death.

Delivery and Handling

Once the dampers have been received, scan them for both visible and inconspicuous damage. If damage is discovered, make a note of it on the bill of lading and proceed to file a claim with the transporter. Verify that all elements of the package, including accessories, are accounted for and accurate.

Dampers need to be kept clean and dry at all times. It is highly advised that you store your items indoors and protect them from dirt, dust, damage, and natural elements. It is advised to not store dampers in temperatures above 100°F.

Pre-Installation Guidelines

The goal of a suitable installation is to attach the control damper into the opening in such a way that damper action is not distorted or disrupted. The checklist below will help you complete the damper installation in a timely and efficient manner.

- 1) Review the schedules to see where the dampers should be installed in the building. Inspect the damper for any signs of damage and dirt.
- 2) When moving the damper, only use the frame or sleeve. Do not use the blades, linkage, actuators, or jackshafts to lift the damper as this could cause damage. Use enough support to raise each section mullion uniformly when handling multi section dampers (see drawing). Avoid excessive bending, twisting, or racking. The damper must not be dragged or stepped on.
- 3) Damper blades need to open and/or close properly. It is not recommended to install screws in the damper frame that interfere with the blade linkage and prohibit this.
- 4) When putting dampers in ducts or apertures they need to be square and not have any twists. Squeezing or stretching the damper into the duct or hole is NOT recommended. Dampers that experience excessive leakage and/or torque needs that exceed damper/actuator design might result from out of square, racked, twisted, or misaligned installations.
- 5) Before and after installation, the damper and actuator must be kept clean, dry, and free of debris, dust, and other foreign materials. Metal shavings, sand, drywall dust, fireproofing materials, plaster, and paint overspray are all examples of foreign materials.
- 6) If wall texturing or spray painting will be done within 10 feet (3 metres) of the damper, the damper should be adequately covered to prevent overspray. Needless dirt and debris on the damper can result in a higher chance of leakage and/or torque needs that are higher than the damper/actuator design.
- 7) In order to maintain, inspect, and service the dampers, appropriate access to dampers and actuators is needed. It will be required to install a removable section of duct if satisfactory size access cannot be accomplished.

Electrical Guidelines:

All electrical and or pneumatic connections to damper actuators should be made in accordance with applicable codes, ordinances and regulations according to region.

Safety Danger

An electrical input may be needed for this equipment. This work should be performed by a qualified electrician only.

Safety Caution

Please verify power requirements before wiring the actuator. Alumavent is not responsible for any damage to, or failure of the unit caused by incorrect field wiring. Electrical and/or pneumatic connections to damper actuators should be made in accordance with wiring and piping diagrams developed in compliance with applicable codes, ordinances and regulations.

Installation Instructions

IMPORTANT: Failure to follow instructions will void all warranties.

IMPORTANT: MODEL SERIES' 3100 AND 3900 DAMPERS WITH VISIBLE/EXPOSED SIDE BLADE LINKAGE INSTALLED IN OR NEAR EXTERIOR WALLS MUST BE INSTALLED WITH EXPOSED LINKAGE TOWARDS INTERIOR OF BUILDING.

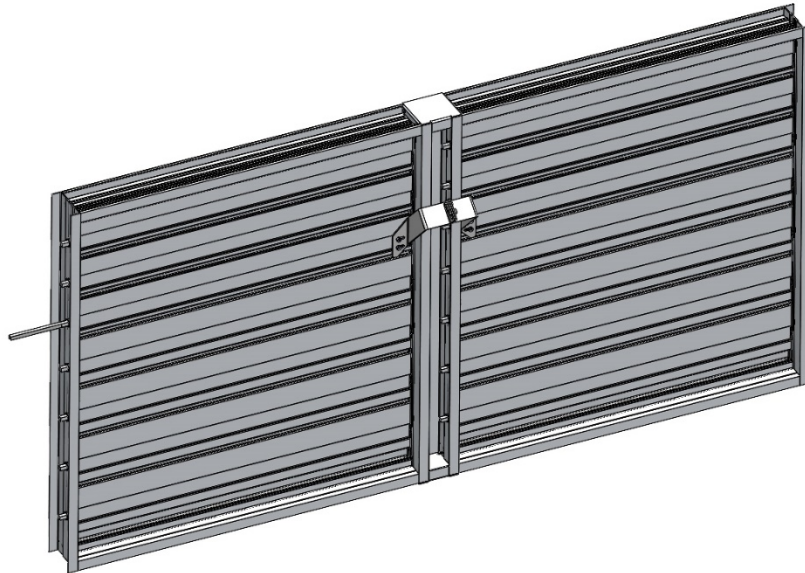

3965 Series shown with jumper and mullion end caps installed

Installation Instructions

See Jackshaft
Instructions



See Jumper
Instructions



The number of sections in a damper assembly is not limited, however they must not exceed the maximum section sizes listed below. Only the largest single piece of these dampers is designed to be self-supporting. Bracing may be required for multiple section damper assemblies to sustain the assembly's weight and keep it from collapsing under system pressure. To support the damper horizontally, Alumavent suggests suitable bracing (installer is responsible for suitable bracing). To avoid sagging due to damper weight, support ductwork in the area of the damper.

Damper Model Series – 3100 & 3900
Section Size – 48''w x 60''h (1219 x 1524)
Max. size for multi section dampers - unlimited

One Section Wide

Each damper section, including multi-section assemblies are required to be square without twisting, bending, or racking. Measure each segment diagonally from the upper corners to the opposite bottom corners.

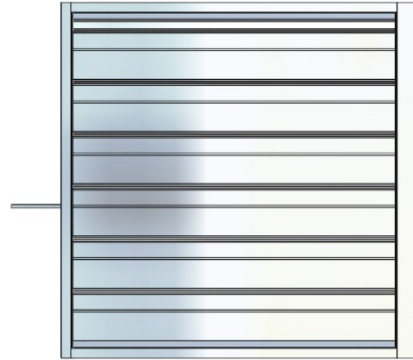

3961 Series

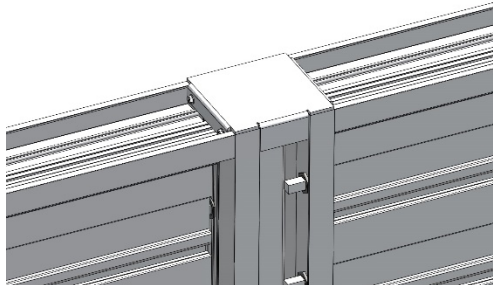
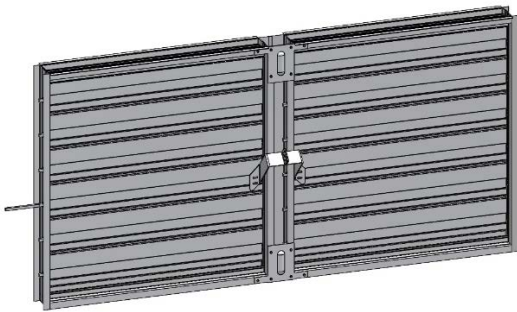

3960 series shown with jumper and multi section brackets installed.

Two Section Wide

Frame members are designed to overlay. The offset overlaying frame comes with fasteners installed. The installer may require bracing. Ensure both sections are parallel, level, and straight to each other. To add strength, add multi-section brackets. Mullion end caps may be used when linkages are to be clear of dirt and debris

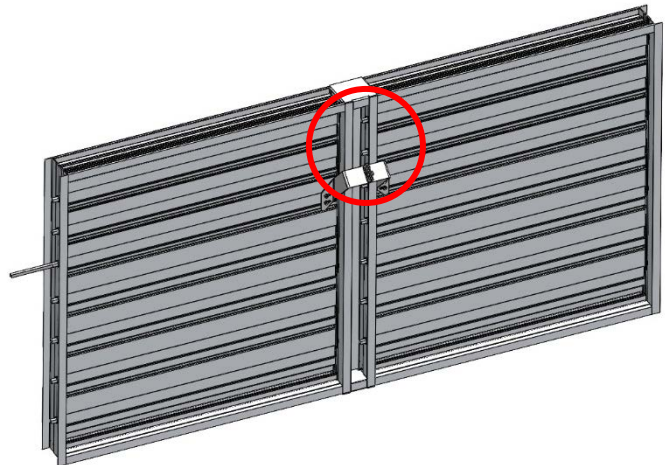

Series shown with mullion end caps. Follow multi section brackets and end cap instructions.

Multiple Section Wide

The bottom sections should be installed first. Set the second level of damper section(s) on top of the bottom section(s), taking into consideration the alignment of all pieces. The installer may require some bracing. It is important to ensuring both sections are straight, even, and parallel to each other. To add strength, use multi-section brackets. Mullion end caps may be used when linkages are to be kept free of dirt and debris (see two sections wide)

3965 Series shown with jumper

(See jumper instructions QR code)

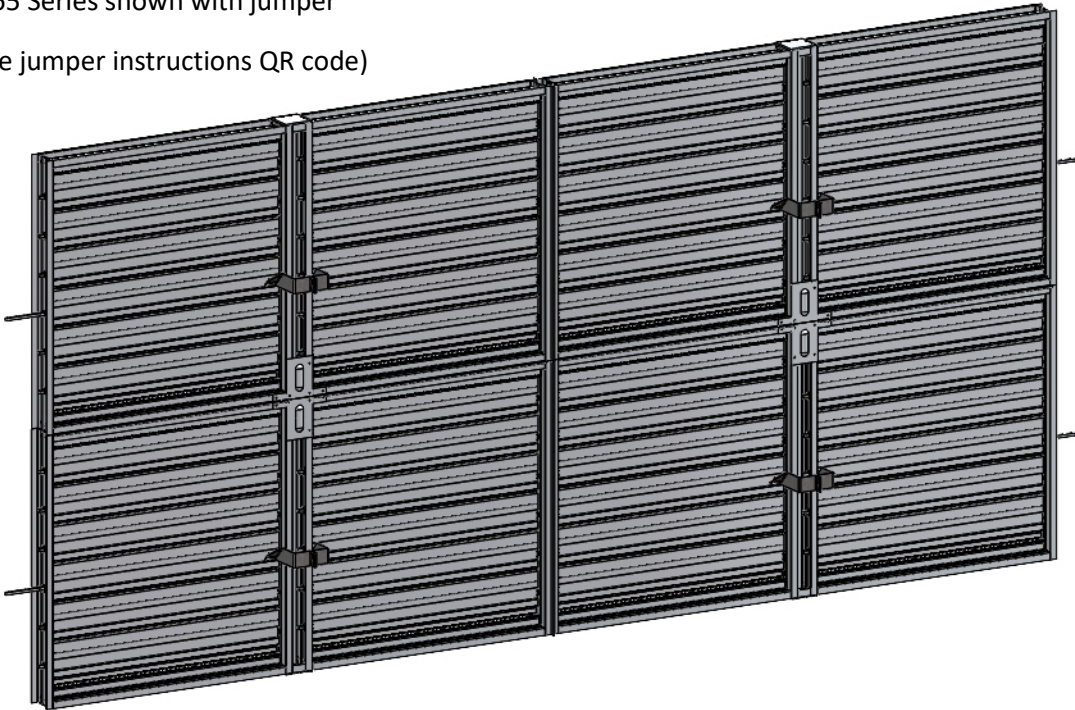

- 1) Shims shall be used between the damper frame and the duct aperture or opening gap to avoid the frame from being distorted by the bolts that hold it in line. To reinforce for strength, brace every horizontal mullion and every 8 feet of damper width vertically. High-velocity dampers (2000 fpm [10.2 m/s]) could require further bracing. Alumavent dampers are built and engineered specifically for structural integrity dependent on model and conditions. The **installer is responsible** for attaching, framing, mating flanges, and anchoring damper assemblies into apertures, ducting, or walls. **Field engineers** should determine the design calculations for these retaining and supporting that particular installation.
- 2) The extension pin should extend roughly 4-6 inches (102-152mm) beyond the frame if the damper actuator is to be installed out of the air stream. For jackshaft units, the jackshaft should extend through the jackshaft bearing assembly and approximately 6 inches (152mm) beyond the frame for jack shafted units.
- 3) Individual damper sections, as well as entire multi-section assemblies, need to be square and without racking, twisting, or bending. Measure each portion diagonally from the upper corners to the opposite bottom corners.
- 4) Damper blades, axles, and linkage must all function freely. Cycle dampers after installation to ensure good operation before starting the system. All portions of a multi-section assembly should open and close at the same time.

Operation:

Ensure that the blades open and close properly while running the damper through its full cycle. Check for slack linkage, especially at the actuator, if there is a problem. Tighten the linkage as required.

Closure:

Remove any unnecessary objects that could hinder blade closure or appropriate blade-to-blade or blade-to-frame seal.

Moving Parts:

Monitor those elements that are supposed to move freely, such as linkages, bearings, and blades, can. Lubricating these components helps to keep them from rusting and accumulating unnecessary friction over time. Only use Moli-spray oil or a related graphite-based dry lubricant since regular lubricating oil attracts dirt more easily. When using ball bearings (without grease fittings) and synthetic, oil-impregnated bearings lubrication is not necessary.

Foreign Matter:

Dirt and dirt can build up over time on damper surfaces. Wipe the damper surfaces with a non-oil-based mild solvent/cleaner to avoid impeding airflow and buildup of debris.

Damper Trouble Shooting:

The following is a cause and correction list for common concerns regarding damper operation:

Symptom	Possible cause	Corrective Action
Damper fails to fully open and/or fully close	Frame is cracked/out of square causing blades to bind on jamb seals	Adjust frame so that it is square and plumb within the duct/opening
	Linkage on actuator is loose	Close damper, disconnect power, adjust and tighten linkage
	Defective actuator	Replace actuator
	Screws in damper linkage	Locate screws and remove or relocate
	The linkage of the actuator is hitting the wall or floor	Damper installed too far into wall. Move out
	Contaminants on damper	Clean with a non oil-based mild solvent/cleaner
Actuator runs hot or makes a humming noise	Actuator prohibited from reaching end of stroke	Disconnect linkage from jackshaft, open damper, power actuator to end of spring, tighten linkage. Verify amperage draw

Warranty

Alumavent warrants this equipment to be free from defects in material and workmanship for a period of one year from the purchase date. Any units or parts which prove to be defective during the warranty period will be repaired or replaced at our option. Alumavent shall not be liable for damages resulting from misapplication or misuse of its products. Alumavent will not be responsible for any installation or removal costs. Alumavent will not be responsible for any service work or back charges without prior written authorization.